

# 100 Watt

## SS 100M10

182mm 36Cells PV Module

### Electrical Characteristics

Module Type	SS 100M10
	STC
Maximum Power- Pmax(W)	100
Open Circuit Voltage - Voc(V)	24.47
Short- Circuit Current - Isc(A)	5.02
Voltage at Pmax -Vmp(V)	21.03
Current at Pmax - Imp(A)	4.76
Module Efficiency - $\eta_m$ (%)	18.16
Power Tolerance(W)	0, +4.99W
Maximum System Voltage(V)	700Vdc (IEC / UL)
Maximum Series Fuse Rating (A)	10A

### Mechanical Specifications

External Dimensions	720*765*30mm
Weight	5.83kg
Solar Cells	Mono crystalline 182X72.8mm (4X9pcs)
Front Glass	3.2 mm tempered glass
Frame	Aluminum
Junction Box	IP67
Output Cables	50cm, length can be customized
Connector	MC4 Compatible
Mechanical Load	Front Side Max. 5400Pa, Rear Side Max. 2400Pa

### Temperature Characteristics

Pmax Temperature Coefficient	-0.350%/ C
Voc Temperature Coefficient	-0.270%/ C
Isc Temperature Coefficient	+0.048%/ C
Operating Temperature	-40~+85 C
Nominal Operating Cell Temperature(NOCT)	45±2 C

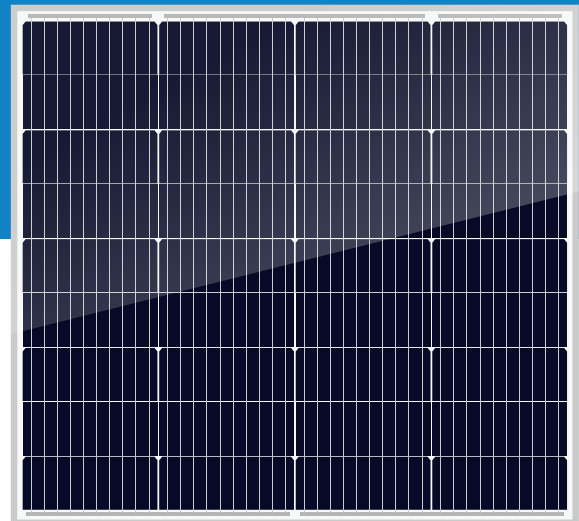

### Packing Configuration

Module Type	SS100M10
Module Dimensions	720*765*30mm
Pallet Dimensions	770*1100*885mm
Pallet Weight	240kg
Pieces/Pallet	36pcs

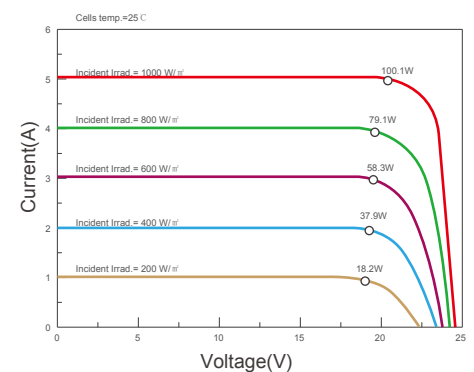
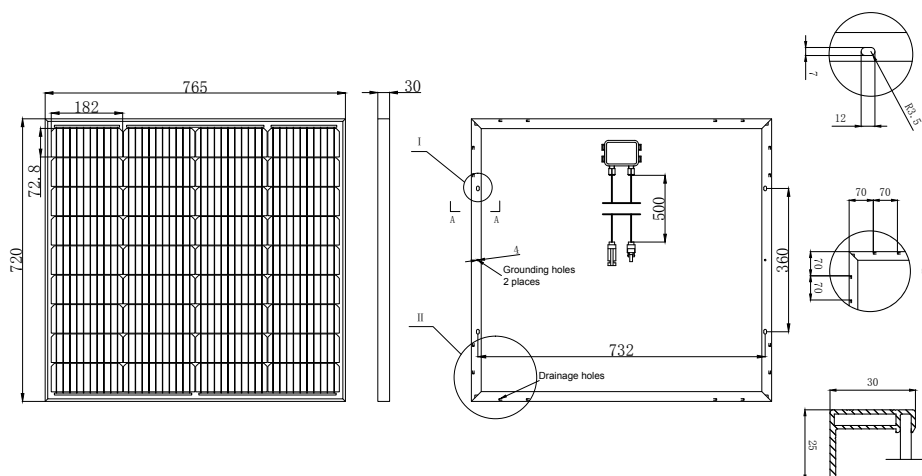

Distributed by : **Northern Sunshine Co.,Ltd.**

82/33 Rattanathibet 26/1, Nonthaburi 11000 Thailand  @nsthai

